

10/02/21

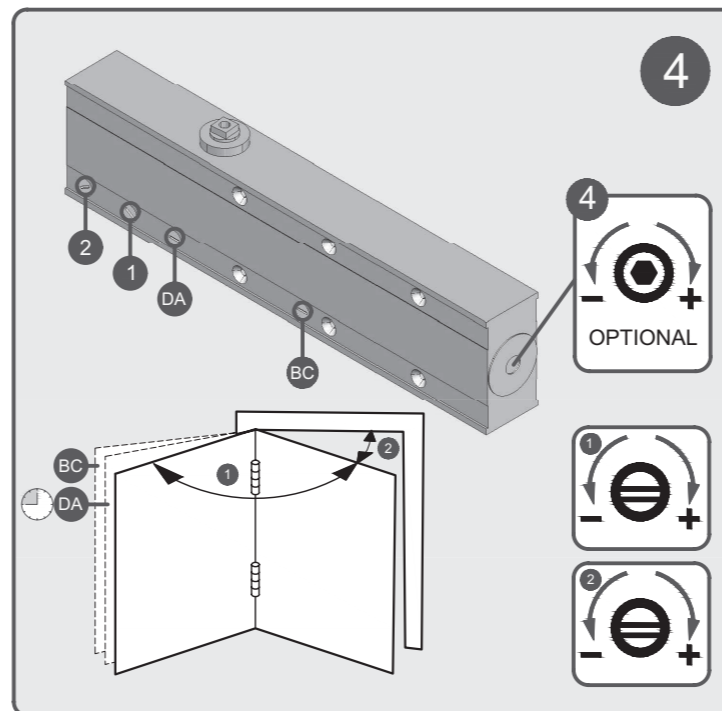

Push Side Fitting - Parallel Arm Code: S-30

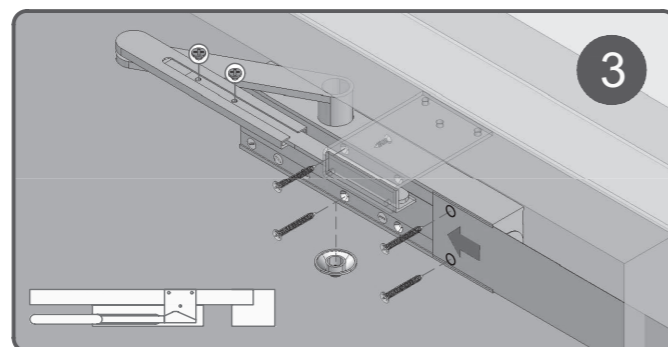
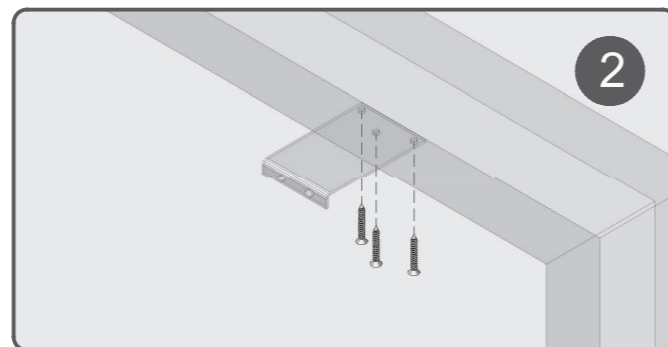
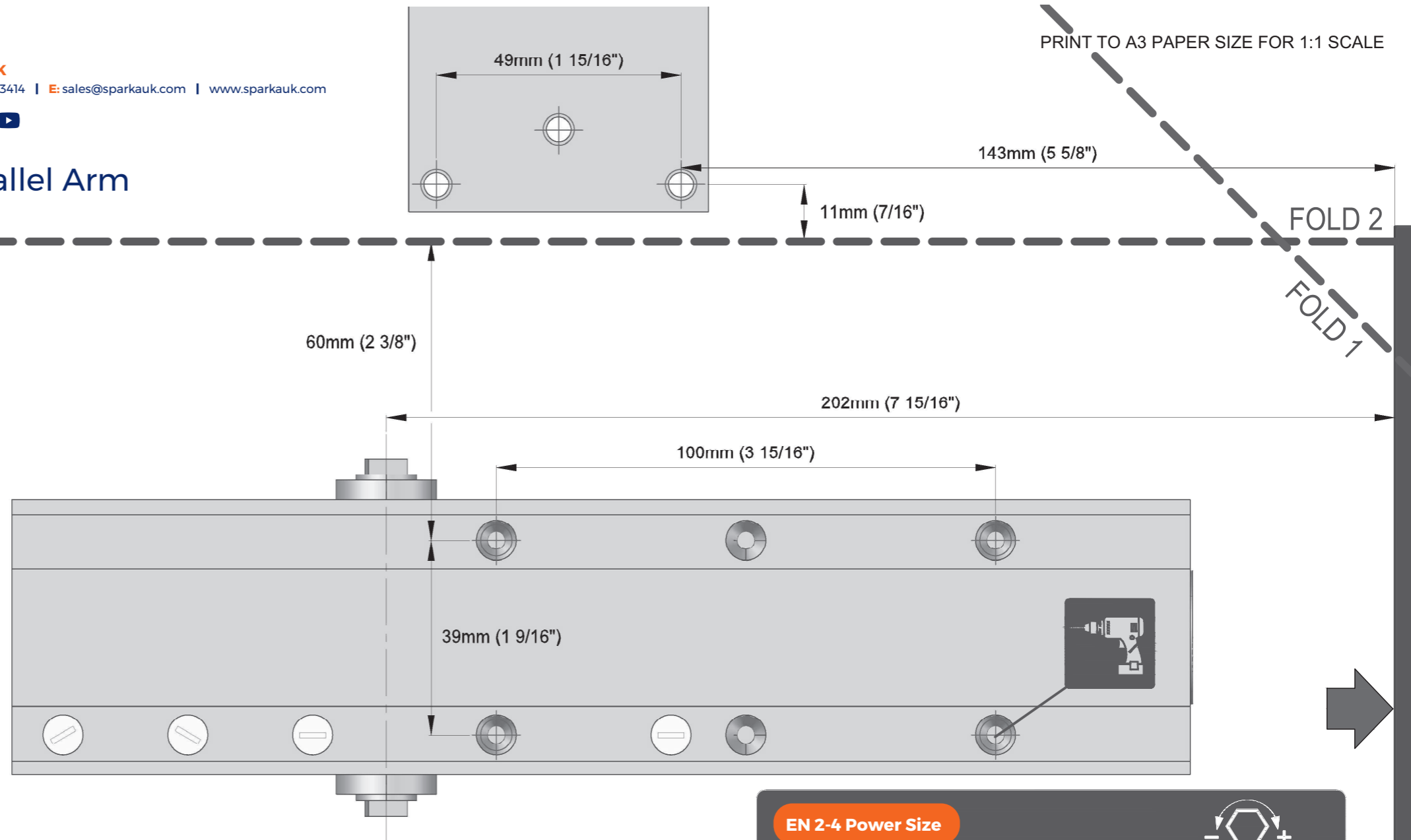
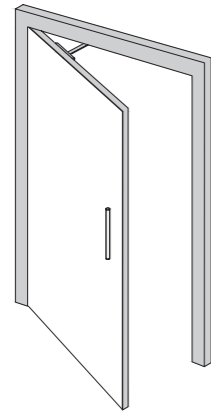

EN 2-4 Power Size

4	No. of turns	EN Size	Max. door width	Max. opening angle
	-5	2	850mm	180°
	*0	3	950mm	180°
	+5	4	1100mm	180°

*** FACTORY PRE-SET**

IMPORTANT NOTES:

DABC VALVES NOT STANDARD, THESE ARE OPTIONAL FOR UNINSULATED STEEL DOORS IP.95M MUST BE USED. THE PINION BOLT MUST BE TIGHTENED TO 12NM.

A MECHANICAL DOOR CLOSER IS NOT DESIGNED TO OVERCOME POOR FITTING, NOR TO OVERCOME EXCESSIVE AIR PRESSURES OR BINDING SMOKE AND WEATHER SEALS. EXCESSIVE AIR PRESSURES CAN BE CREATED BY THROUGH DRAFT, BY AIR CONDITIONING, BY SMALL ROOMS WITHOUT VENTILATION, OR WHERE NO AIR TRANSFERS GRILLS ARE FITTED. MECHANICAL DOOR CLOSERS ARE DESIGNED TO CLOSE THE STATED AND TESTED SPECIFICATION OF DOOR WEIGHT AND DOORSETS/DOOR ASSEMBLIES WHEN DOORS ARE FITTED WITH CORRECT GAPS AND NOT BINDING ON SEALS. IF YOU ENCOUNTER PROBLEMS WITH DOORS NOT CLOSING PLEASE WATCH OUR "6 WAYS TO TROUBLESHOOT A DOOR CLOSER" VIDEO ONLINE. WHERE DOORS ARE NOT CLOSING DUE TO AIR PRESSURES THEN PROFESSIONAL ADVICE FROM AN AUTHORISED INSTALLER IS RECOMMENDED TO FIT FIRE TESTED AND THIRD PARTY CERTIFICATED AIR TRANSFER GRILLS, AND/OR AUTOMATIC DOOR OPERATORS.

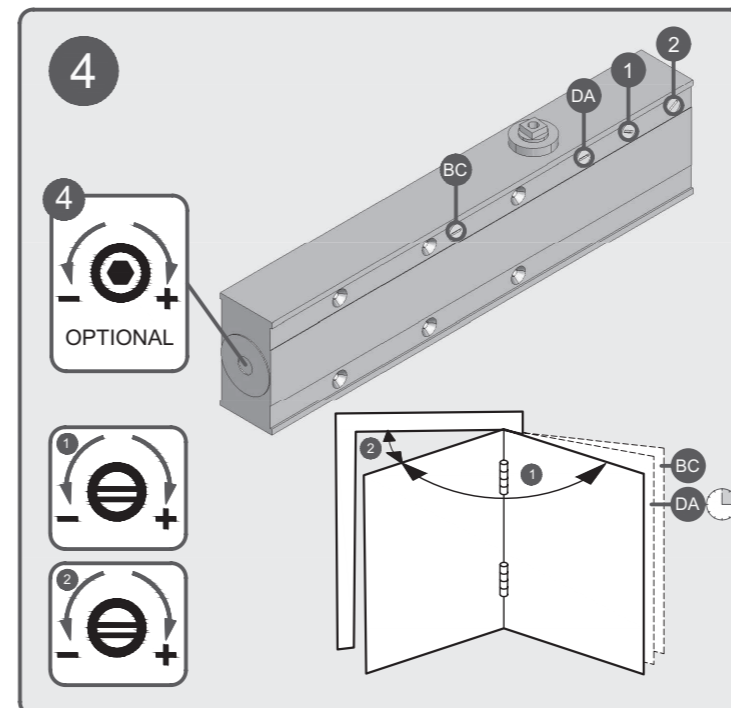
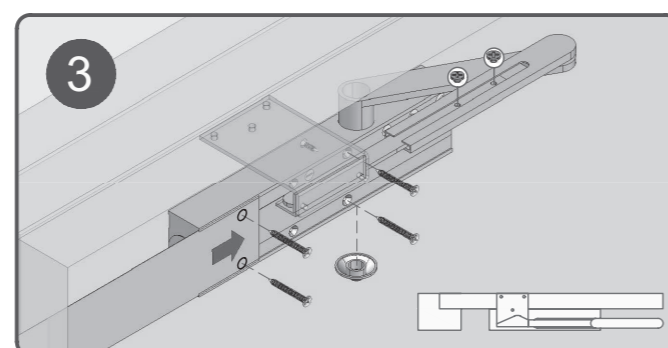
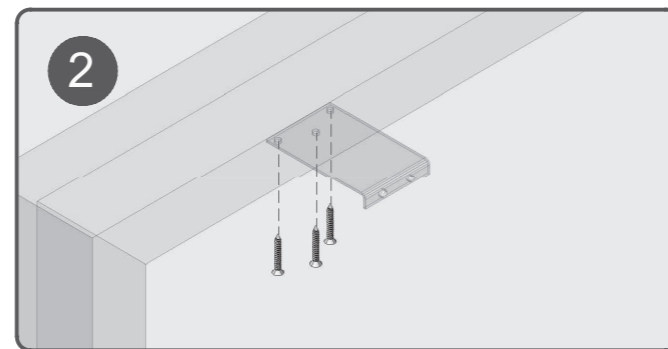
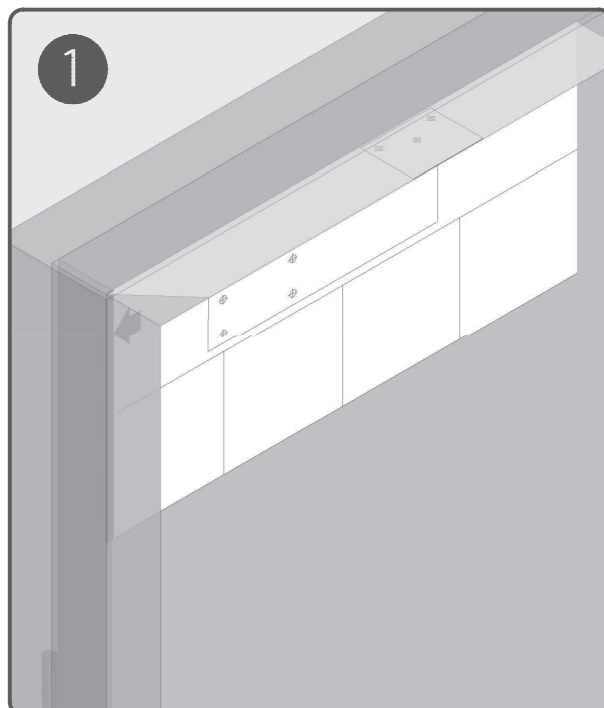
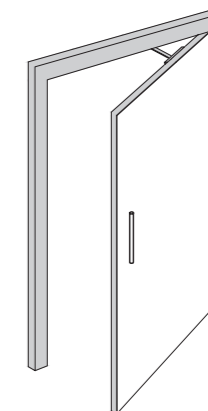
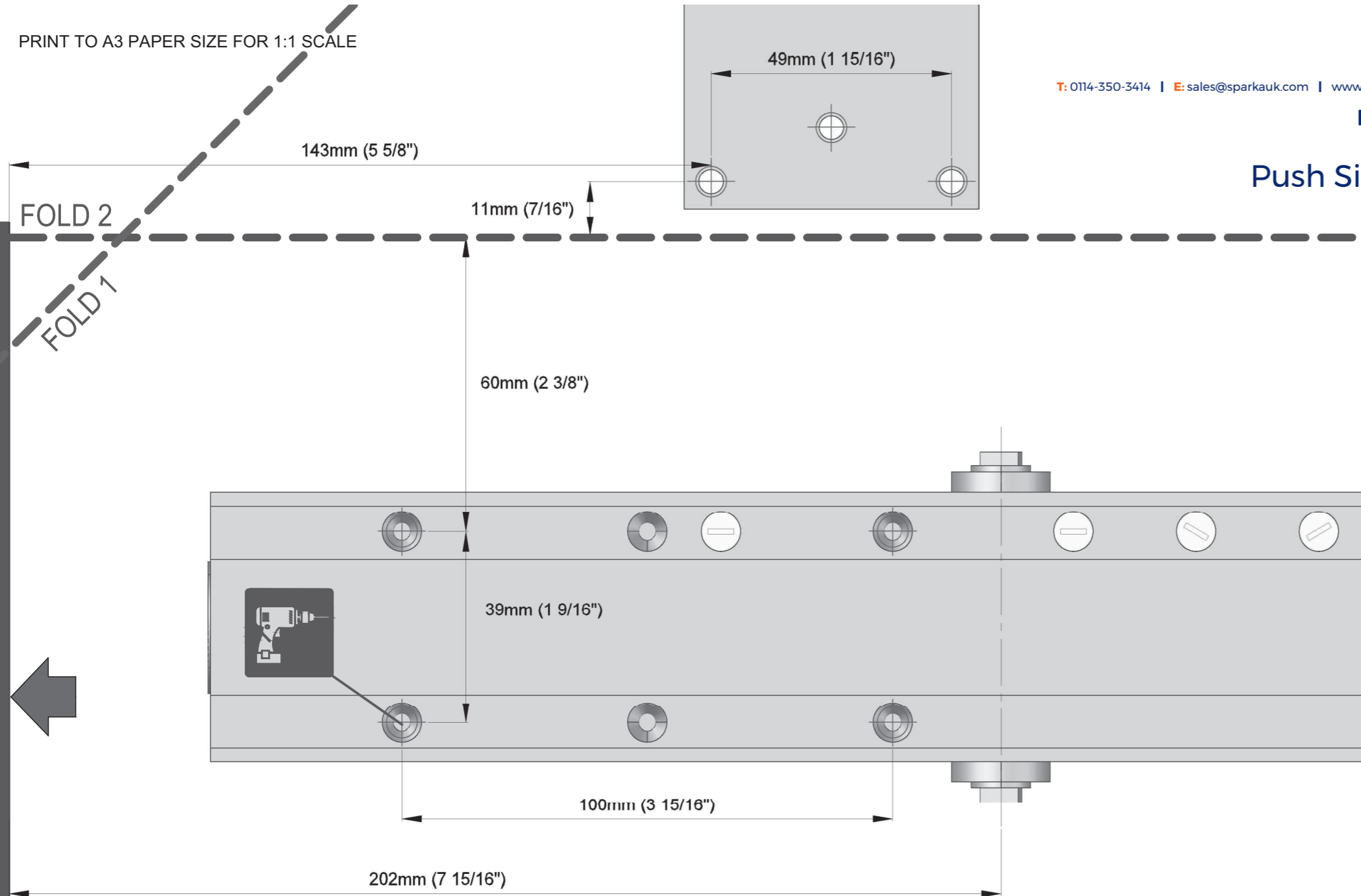

EN 2-4 Power Size

No. of turns	EN Size	Max. door width	Max. opening angle
-5	2	850mm	180°
*0	3	950mm	180°
+5	4	1100mm	180°

* FACTORY PRE-SET

IMPORTANT NOTES:

DABC VALVES NOT STANDARD, THESE ARE OPTIONAL FOR UNINSULATED STEEL DOORS IP.95M MUST BE USED. THE PINION BOLT MUST BE TIGHTENED TO 12NM.

A MECHANICAL DOOR CLOSER IS NOT DESIGNED TO OVERCOME POOR FITTING, NOR TO OVERCOME EXCESSIVE AIR PRESSURES OR BINDING SMOKE AND WEATHER SEALS. EXCESSIVE AIR PRESSURES CAN BE CREATED BY THROUGH DRAFT, BY AIR CONDITIONING, BY SMALL ROOMS WITHOUT VENTILATION, OR WHERE NO AIR TRANSFERS GRILLS ARE FITTED. MECHANICAL DOOR CLOSERS ARE DESIGNED TO CLOSE THE STATED AND TESTED SPECIFICATION OF DOOR WEIGHT AND DOORSETS/DOOR ASSEMBLIES WHEN DOORS ARE FITTED WITH CORRECT GAPS AND NOT BINDING ON SEALS. IF YOU ENCOUNTER PROBLEMS WITH DOORS NOT CLOSING PLEASE WATCH OUR '6 WAYS TO TROUBLESHOOT A DOOR CLOSER' VIDEO ONLINE. WHERE DOORS ARE NOT CLOSING DUE TO AIR PRESSURES THEN PROFESSIONAL ADVICE FROM AN AUTHORISED INSTALLER IS RECOMMENDED TO FIT FIRE TESTED AND THIRD PARTY CERTIFICATED AIR TRANSFER GRILLS, AND/OR AUTOMATIC DOOR OPERATORS.